

# 5-10 HP Reciprocating Compressors

1980-2010  
**30**  
YEARS



Distributed by:



## Compressed Air Systems

Simplicity. It's What We Do

Compressed Air Systems, LLC 2626 Skyway Drive Grand Prairie, TX, 75052 1-800-531-9656 Fax 972-352-6364

[www.compressed-air-systems.com](http://www.compressed-air-systems.com)

# CA1 and CA2 pump features



Disc and spring valves for long reliable service

Mounted cast iron intercooler for long life and finned for maximum cooling

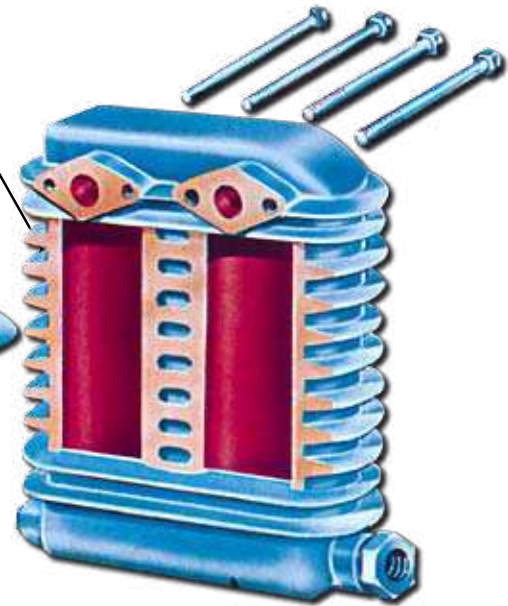

Solid cast iron cylinder head for heavy duty use

Valves accessed from top of head for easy maintenance

Wrist pin needle bearings increase pump life and make maintenance simple

Solid cast iron cylinders precision honed for excellent oil control and long run life

Oil control ring as well as three compression rings ensure long run life and high efficiency

Centrifugal unloader allows load less starts in all conditions

Heavy duty over sized tapered roller bearings on both ends of crank shaft provide long run life and easy maintenance

Heavy duty large diameter crank shaft provide long run life, pump stability and inertia

Pump lower end inspection plate provides easy maintenance

Solid cast iron crank case reduces vibration and noise

Automotive style bearings on rods provide longer rod life and easy maintenance

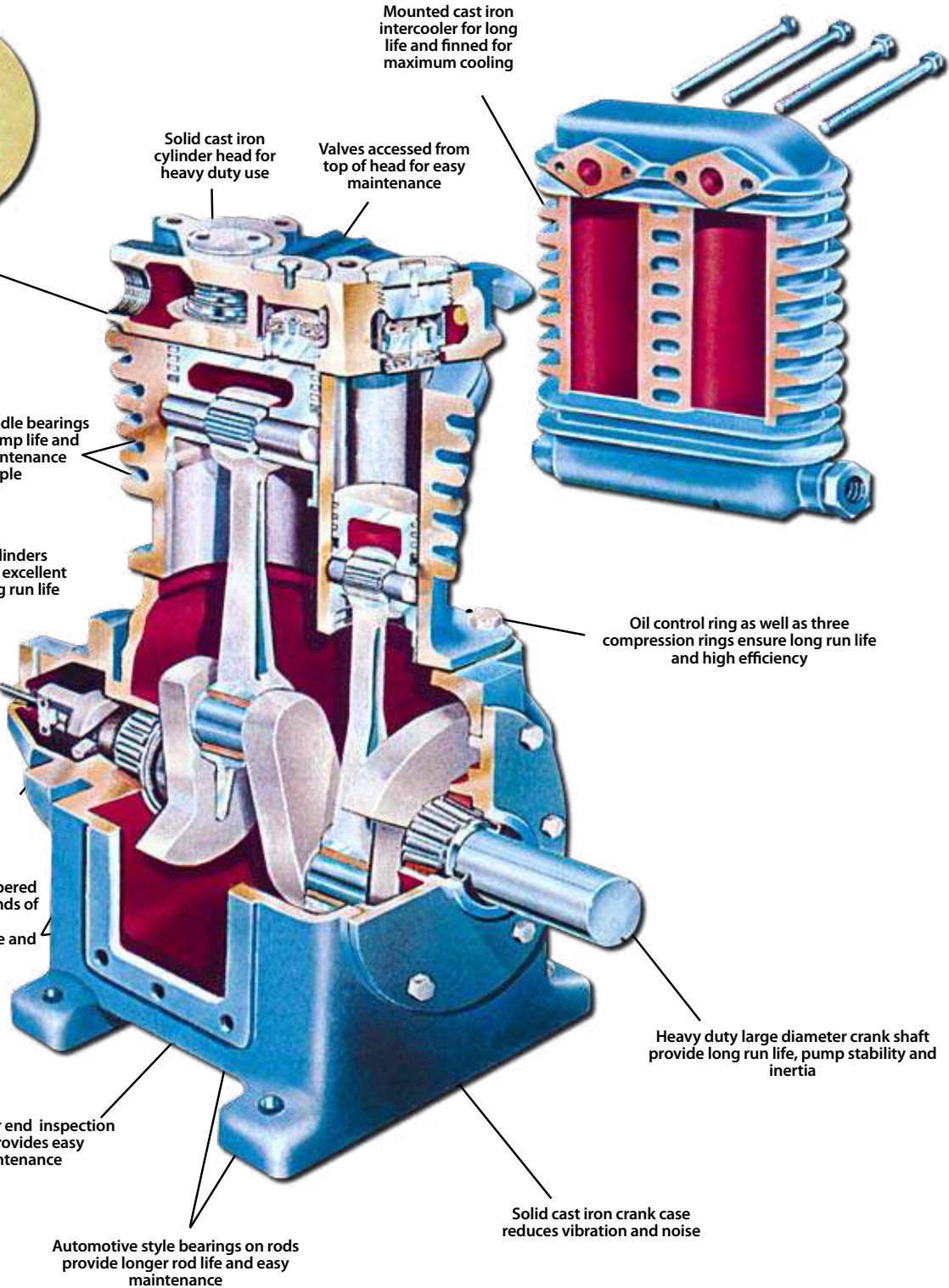

# Industrial Series

## 5-15 HP Large Industrial Duty Air Compressors

The CAS Industrial Series compressors are designed for Automotive and Industrial applications. The CA1 and CA2 pumps are manufactured for durability and long life. The units feature some of the most heavy duty components found in piston compressors today. The units run at a low RPM to provide reliable air for your application.

- Solid cast iron pump
- Disc and spring valves
- Centrifugal unloader
- Low pump rpm
- Oil sight glass
- Oil drain and fill on front of compressor pump
- 70% duty cycle
- Heavy duty NEMA motors
- OSHA style totally enclosed belt guard
- ASME code receivers

### Accessories Available

- Hour Meter
- Belt Guard mounted aftercooler
- HOA operating switch
- Automatic Tank Drain
- Alternating relay
- Magnetic Motor Starter NEMA1
- Intake silencer
- Low Oil monitor
- Dual control constant run
- Rubber mounting pads
- TEFC motor
- Nema 4 control enclosure
- Explosion proof motor
- Explosion Proof control enclosure

CA-1 PUMP									
Model	H/P	CFM @ 175	CFM @ 100	Tank	Pump	Vert/Hz	Volt	Amp Draw 230 Volt	Weight
B51V80-CA1B	5	17.5	19	80	CA1B	V	208/230/1	24	605
B51V84	5	19	20	80	CA1	V	208/230/1	24	605
B53V84	5	19	20	80	CA1	V	208/230/480/3	16	605
B51H84	5	19	20	80	CA1	H	208/230/1	24	605
B53H84	5	19	20	80	CA1	H	208/230/480/3	16	605
B71V84	7.5	24	25	80	CA1	V	208/230/1	32	615
B73V84	7.5	24	25	80	CA1	V	208/230/480/3	18	615
B71H84	7.5	24	25	80	CA1	H	208/230/1	32	615
B73H84	7.5	24	25	80	CA1	H	208/230/480/3	18	615
B71V124	7.5	24	25	120	CA1	V	208/230/1	32	690
B73V124	7.5	24	25	120	CA1	V	208/230/480/3	18	690
B71H124	7.5	24	25	120	CA1	H	208/230/1	32	690
B73H124	7.5	24	25	120	CA1	H	208/230/480/3	18	690
CA-2 PUMP									
Model	H/P	CFM @ 175	CFM @ 100	Tank	Pump	Vert Hz	Volt	Amp Draw 230 Volt	Weight
B71V86	7.5	30.5	32	80	CA2	V	208/230/1	32	700
B73V86	7.5	30.5	32	80	CA2	V	208/230/480/3	18	700
B71H86	7.5	30.5	32	80	CA2	H	208/230/1	32	700
B73H86	7.5	30.5	32	80	CA2	H	208/230/480/3	18	700
B71V126	7.5	30.5	32	120	CA2	V	208/230/1	32	750
B73V126	7.5	30.5	32	120	CA2	V	208/230/480/3	18	750
B71H126	7.5	30.5	32	120	CA2	H	208/230/1	32	750
B73H126	7.5	30.5	32	120	CA2	H	208/230/480/3	18	750
B101V86	10	35.4	38	80	CA2	V	208/230/1	42	735
B103V86	10	35.4	38	80	CA2	V	208/230/480/3	28	725
B101H86	10	35.4	38	80	CA2	H	208/230/1	42	735
B103H86	10	35.4	38	80	CA2	H	208/230/480/3	28	725
B101V126	10	35.4	38	120	CA2	V	208/230/1	42	750
B103V126	10	35.4	38	120	CA2	V	208/230/480/3	28	750
B101H126	10	35.4	38	120	CA2	H	208/230/1	42	750
B103H126	10	35.4	38	120	CA2	H	208/230/480/3	28	750
B153V126	15	40.1	41	120	CA2	V	208/230/480/3	42	750
B153H126	15	40.1	41	120	CA2	H	208/230/480/3	42	725

All industrial stationary units require magnetic starter.



# Elite Series

## Stationary Commercial Compressors

CAS Elite Series compressors feature a unique option package that makes your new compressor simpler to maintain and deliver higher quality air. The Elite options are available on all stationary compressors.



**1 Belt guard cooler** delivers air at a much cooler temperature to the receiver. Compressed air that goes into the receiver cool drops more moisture in the receiver. The moisture is then automatically drained from the receiver. That means less equipment damaging moisture is sent into your air lines.

**2 Low oil monitor** will help to keep you notified when you need to add oil to the compressor pump.

**3 Magnetic motor starter** protects your motor from overload and makes the important electrical contact to get the motor running.

**4 Vibration isolators** are designed to protect your receiver from damage caused by vibration when the compressor is running.

**5 Automatic tank drain** will help with the daily tank maintenance so that you don't have to.

\* Belt guard cooler not included on 5hp models

**FREIGHT  
PREPAID**

### Accessories Available for Elite Units

- Hour Meter
- HOA operating switch
- Alternating relay
- Intake silencer
- Dual control constant run

- Rubber mounting pads
- TEFC motor
- Nema 4 control enclosure
- Explosion proof motor
- Explosion proof control enclosure



### Compressed Air Systems, LLC

2626 Skyway Drive  
Grand Prairie, TX, 75052

**1-800-531-9656**

Fax 972-352-6364

**Simplicity. It's What We Do.**